



New Model : HCD-X1501-40

HCD-X1501-40 is developed as a part of HCD series.

Basic features and functions are same as basic model HCD-1501-40, but embroidery area is expanded to 400 x 1,200mm (Y x X).



SPECIFICATIONS

MODEL	Embroidery Area(Y x X)					Number of Needles	Max. Speed (r.p.m.)
	Wide Border Frame	Border Frame	Wide Cap Frame	Low-Profile Cap Frame	Largest Tubular Frame Size		
HCD-X1501-40	400 x 1,200mm 15.7x47.2inch	400 x 520mm 15.7x20.5inch	80 x 360mm 3.1 x 14.2inch	70 x 180mm 2.8x7.1inch	420 x 440mm 16.5x20.5inch	15	800 rpm

STANDARD ACCESSARIES

- 8.9inch Wide Color LCD Monitor
- Happy Link / Happy LAN software
- Wide Border Frame (400 x1,200mm)
- Border Table
- Tubular Frames
 - 2x Round Frame PTA-12-360
 - 2x Round Frame PTA-15-360
 - 2x Square Frame PTA-32320-360
 - 2x Square Wooden Frame WS-42440-520

OPTIONS

- Wide Cap Frame
- Low-Profile Cap Frame
- Tubular Frame Preparation Table
- Upper Thread Holder
- Laser Position Marker
- Floppy Disk Drive Unit
- Bobbin Thread Winder
- Border Frame(400x1,200mm)
- Front Safety Sensor(Needle Sensor)
- Front Table
- Expand Side Table (right and left)
- Additional Memory (500,000stitches/pc)
- Round Frame PTA-18-360
- Round Frame PTA-21-360



Possible Operation with Option

= with Expand Side Table =



Max.Speed : 800 r.p.m.

= with Cap Frame =



Max.Speed : 850 r.p.m.

= with Border Frame(400x520mm) =



Max.Speed : 900 r.p.m.

= with Tubular Frame =



Max.Speed : 1,000 r.p.m.



Modification from HCD-1501-40

Basic Model HCD-1501-40 can be modified to HCD-X1501-40 with the following Spare Parts:

120cm X-Carriage

Parts No.: HCDU24040

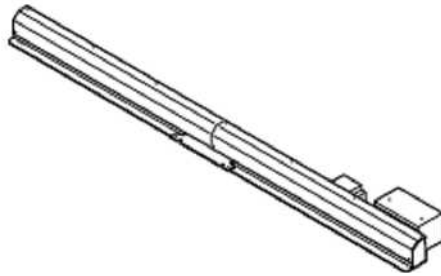

Wide Border Frame Set

Parts No.: HCDU37100

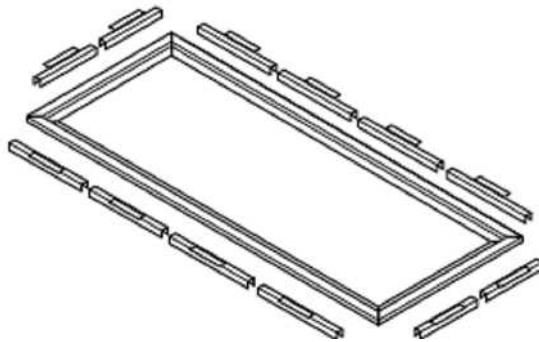

Border Table Set

Parts No.: HCD930020

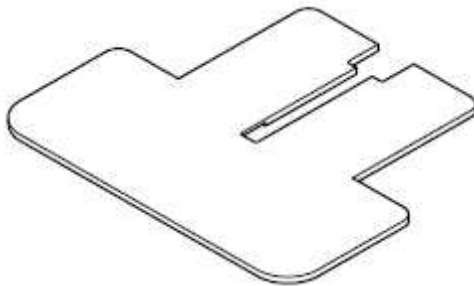

Expand Side Table Set

Parts No.: HCDU37030

